



Consistency Data of Peak Expiration Flow, SpO₂ Level and Heart Rate Measurement using Spirometer Volume (*SpiroLuME*) Device

Muhammad Amir Aikal Azmin

Human Engineering Group (HEG), Faculty of Mechanical & Automotive Engineering Technology, Universiti Malaysia Pahang Al-Sultan Abdullah (UMPSA), 26600 Pekan, Pahang, Malaysia

Mohd Azrul Hisham Mohd Adib*

Human Engineering Group (HEG), Faculty of Mechanical & Automotive Engineering Technology, Universiti Malaysia Pahang Al-Sultan Abdullah (UMPSA), 26600 Pekan, Pahang, Malaysia

Medical Engineering & Health Intervention Team (MedEHIT), Centre for Advanced Industrial Technology (AIT), Universiti Malaysia Pahang Al-Sultan Abdullah (UMPSA), 26600 Pekan, Pahang, Malaysia

[*Corresponding author]

Abstract

Currently, most respiratory system equipment has constraints preventing rapid and straightforward readings. Additionally, respiratory disorders require continual attention. To address this issue, the Spirometer volume so-called *SpiroLuME* device has been successfully developed to observe lung capacity performance. This research attempts to evaluate the reliability of the device's data using accurate patient information. Arduino Nano serves as the microprocessor, pressure sensor, oximeter sensor, and LCD screen display for the *SpiroLuME* device. The device can monitor and measure the user's peak expiratory flow (PEF), SpO₂, and heart rate. Based on the preliminary test, the typical values range from 3.5 to 7 L/s, or 50 to 80 percent of the patients' maximum flow rate, at a heart rate between 60 and 96 beats per minute. Moreover, the oxygen level data range is 94% to 98%. The efficiency of the device has been compared with the existing device. As a result, the *SpiroLuME* device provides accurate and consistent PEF, SpO₂, and heart rate readings for all patients.

Keywords

Lung Capacity, Spirometer, Volume, Flow, Respiratory System, SpO₂ Level, Oxygen Level

INTRODUCTION

Extreme climate change and air pollution result from dust, smoke, and gas emissions. Automobile and industrial trash can increase the risk of contracting several diseases. [1-2]. Particularly respiratory illnesses that are caused by viruses. The spirometer gadget was just an upside-down calibrated bucket immersed in water. The volume of expelled air from completely expanded lungs could be precisely quantified by exhaling into a tube to a bucket. Dr Hutchinson invented the phrase "vital capacity," also known as "capacity for life," when he found that a reduction in this important indicator was predictive of early death. [3]. A spirometer measures airflow. Using the time-integrated airflow signal, the change in air volume is calculated. [4]. The gadget also monitors the amount of air a person may intake and exhale over a specific period. This measurement is frequently used to diagnose lung disorders, including obstruction and remodeling. [5]. The primary objective of office spirometry is to evaluate a patient's exhalation force and discriminate between obstructive and restrictive lung disease based on the test's results. The force of exhalation can be assessed in terms of volume or flow. [6]. The lungs are related to blood circulation and are part of the respiratory system. Less oxygen in the body will affect the human body's health system, producing asthma and anemia in the circulatory and respiratory systems, respectively. It is the only organ having two circulations: the pulmonary circulation, whose primary function is gas exchange, and the bronchial circulation, which supplies oxygenated blood to the airway walls, pulmonary arteries, and pulmonary veins. Despite low intravascular arterial pressure, pulmonary circulation may sustain a high blood flow and accommodate cardiac output. [7,10,11]. Age, height, and gender are the only factors determining lung capacity and volume. Physical activity can alter lung capacity. The lung capacity of athletes, laborers, and coolies is greater than that of office workers.

Lung disease or asthma reduces lung capacity. Asthma narrows the airways, hence decreasing lung airflow. Lung volume decreased [8-9].

However, the lack of experts in the production of devices to test lung capacity in measuring and undergoing lung rehabilitation training is essential. So, the research or fabrication process to create the *SpiroLuME* device has been successfully developed. In this study, we aim to test the consistency of data obtained from the *SpiroLuME* device using real patients.

MATERIALS AND METHODS

Peak Expiratory Flow (PEF)

Peak expiratory flow (PEF) is the most significant flow recorded from full inspiration to full inspiration during a forced expiratory vital capacity test. In healthy individuals, the index assesses the diameter of the central airways and the force exerted by the expiratory muscles. [10-11]. PEF is widely used to treat patients with variable airflow limitation, which is heavily impacted by the size of the peripheral airways. The indicator correlates with effort level. The conclusions are influenced by the commonly recognized definition of peak flow, including its duration. Comparing the obtained data to those of other devices takes work. Therefore, further work is necessary. [12-13]. The maximal expiratory flow at a given lung volume is the most outstanding expiratory flow achievable at a given lung volume by performing a forced expiratory maneuver beginning at the terminal lung capacity (TLC). A whole-body plethysmograph can detect alterations in lung capacity through the mouth or chest. The first method does not account for the reduction in lung capacity caused by the compression of alveolar gas during forced expiration. Consequently, the outputs of the two techniques may vary considerably. This decrease reduces the lung's elastic rebound and airway diameter [14-15].

Heart Rate (HR) and Oxygen Level (SpO₂)

Oxygen saturation is defined as the detection of Hemoglobin and Deoxyhemo-globin to determine the quantity of oxygen dissolved in the blood. Standard monitoring equipment in contemporary hospitals is the pulse oximeter [16-17]. Pulse oximeters have the potential to serve as diagnostic tools for respiratory and cardiovascular conditions. This innovation has dramatically reduced the mortality risk associated with anesthesia and surgery [18-19]. SpO₂ represents the ratio of oxygen-bound to unbound hemoglobin molecules. A healthy person has a 95% oxygen saturation level. A decrease below 95% indicates an imbalance in oxygen delivery or consumption, such as that caused by an impeded gas exchange in the lungs as a result of severe respiratory diseases like pneumonia and asthma or by an increase in consumption and impeded gas exchange as observed in other systemic inflammatory and infectious diseases-es. Most individuals have heart rates between 60 and 100 beats per minute (bpm). Anxiety, stress, hormones, drugs, and physical activity can affect a person's heart rate. [20-21].

Development of *SpiroLuME* Device

The SolidWorks 3D CAD software was used to create the three-dimensional design of the *SpiroLuME* device. The sensor unit and hand wrap are detachable to facilitate storage. The device's housing is 3D-printed using PLA filament to assist in installing the electrical sensor. As seen in **Figure 1**, the *SpiroLuME* device consists of an electrical box, a 5V battery, and various electronic components. This concept has three applications: heart rate, oxygen level (SpO₂), and peak expiratory flow (PEF).

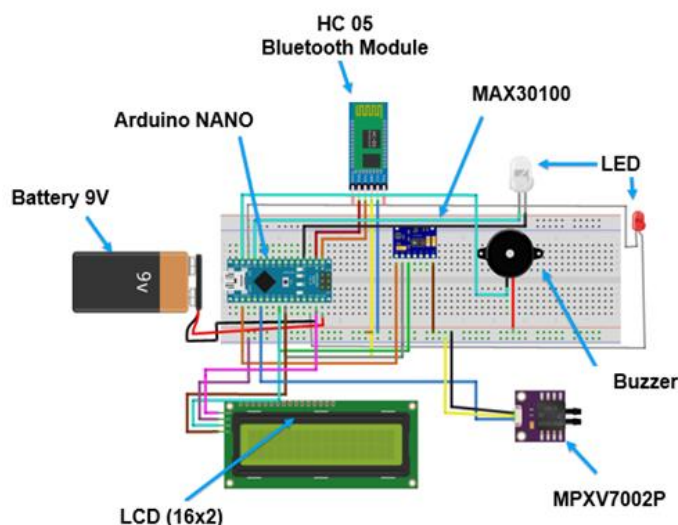

Fig. 1 Electric and electronic circuit diagram for the *SpiroLuME* device

This device features an external controller and displays to reduce the number of electronic components inside. The device enables users to monitor real-time health data and receive phone notifications immediately. In addition, the internal battery is intended to be recharged using the Android cable. This *SpiroLuME* device featured a mouthpiece with a single usage. The purpose of this mouthpiece is to expel air from the mouth. The sensor MPXV7002DP is the input of an

instrumentation amplifier. The MPXV7002DP is a dual-port, 8-pin SOIC integrated silicon pressure sensor. This sophisticated monolithic silicon pressure sensor is suitable for many applications. The A/D inputs are beneficial for microcontrollers and microprocessor users. This pressure transducer uses complex micromachining techniques, thin-layer metallic-station, and bipolar processing to provide a precise, high-level, pressure-proportional analog output signal. In addition, a heart-rate pulse sensor from MAX30100 is used to measure pulse oximetry and heart rate simultaneously. After collecting microcontroller output data, the gadget of this monitoring system shows PEF, heart rate, and SpO₂ through LCD. Due to its tiny size, which enables device connection, Arduino mini is selected as a microcontroller. The LCD will display the results of the measurements. An LED light and a buzzer will alert the patient if he or she has yet to reach the target.

Component of SpiroLuME Device

In this study, a mouth blow was amplified using an instrumentation amplifier to assess peak expiratory flow (PEF). The default analog-to-digital (A/D) converter of the Arduino NANO is used to convert analog to digital data, which is then translated to volume units using the venturi meter method and the analysis of SpO₂ and heart rate. The volume measurement and oximeter results will be shown on an LCD. The mobile applications are designed to display the patient's peak expiratory flow as shown in **Table 1**, SpO₂ level, and heart rate, as illustrated in **Figure 2**.

Table 1 Peak expiratory flow measuring indicator

Result	Level	Description
≥ 7	High	Well-regulated. The lung is healthy and in good condition
3 – 7	Medium	Getting worse or is poorly controlled.
≥ 3	Low	It requires emergency care.

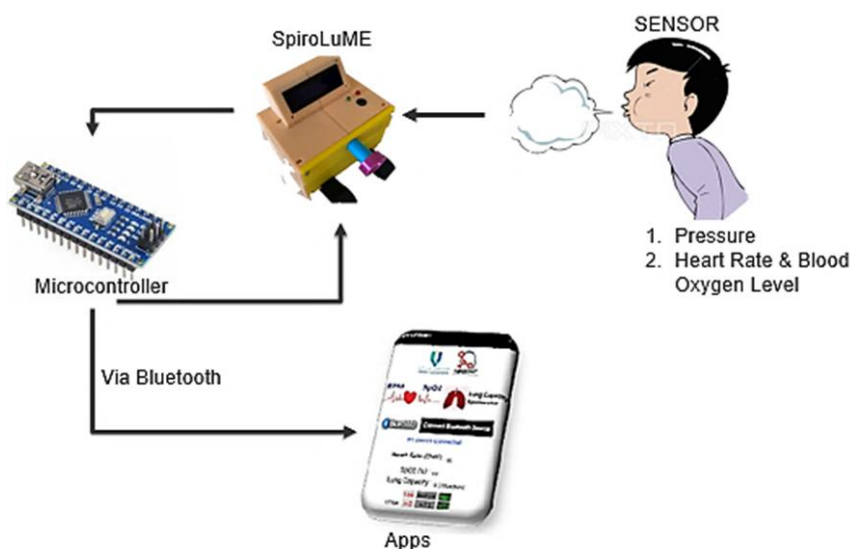

Fig. 2 Illustrated the details operation process flow of the *SpiroLuME* device integrated with mobile apps.

RESULTS AND DISCUSSION

The *SpiroLuME* device is well-designed and developed as shown in **Figure 3**. The device is integrated with mobile apps and can determine a patient's lungs' peak expiratory flow volume and provide healthcare monitoring via smartphone applications. The *SpiroLuME* device also can be fitted with an oximeter sensor. In addition, the *SpiroLuME* device is equipped with an indicator and a display to alert the clinician when a parameter value reaches an abnormally high or low value.

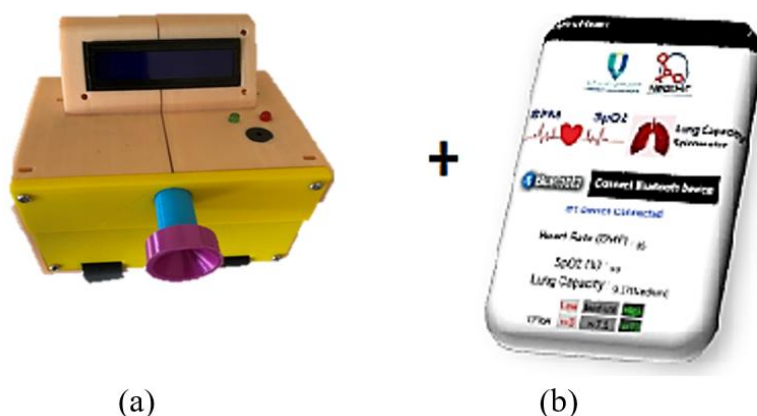

Fig. 3. (a) The prototype of the *SpiroLuME* device; and (b) The MIT apps inventor

SpiroLuME Device

The *SpiroLuME* device is equipped with a pressure sensor, heart rate, and oxygen (SpO₂) level. The design's apex includes an LCD for monitoring each sensor. Approximately 9 volts are needed to activate the monitoring sensor. Before this monitoring system can be utilized, Bluetooth must be enabled. The *SpiroLuME* device will transmit data to the MIT apps. developer to show data on the smartphone's display. LCD allows for one display to be connected. Peak expiratory flow, heart rate, and blood oxygen levels are shown on the LCD screen.

Preliminary Consistency Test

Test preliminary consistency tests have been done with 9 data patients. All the participants come from different backgrounds. All the test was performed 5 times to test the level of consistency of the data sent on the mobile apps. According to the graph, emergency care is required between 0 and 3.5L/s. Their lung capacity and output are below fifty percent of their peak levels. This can also warn asthmatics of upcoming episodes. A physician must identify the patient's symptoms. The average values are 3.5–7 L/s or 50%–80% of the maximal flow rate of the patient. The patient is in good health. The volumetric flow rate is 7 L/s. Their highest output ranges from 80% to 100%. Thus, their lung capacity is maximized, showing that they have healthy lungs and adopt a healthy lifestyle. The graph shows users lowering their breathing rate. As shown in **Figure 4**, after *SpiroLuME* testing, some people seem tired and have a large gap between the *RossMax* and *SpiroLuME* devices. 77% of patients have medical device similarity data. Devices differ in 2–3% of patient data. Smokers and poor lifestyles show a considerable decline in the graph above. Because their muscles are fatigued, these groups' respiration rate has slowed. Recent evidence suggests that all users have distinct pulmonary illnesses.

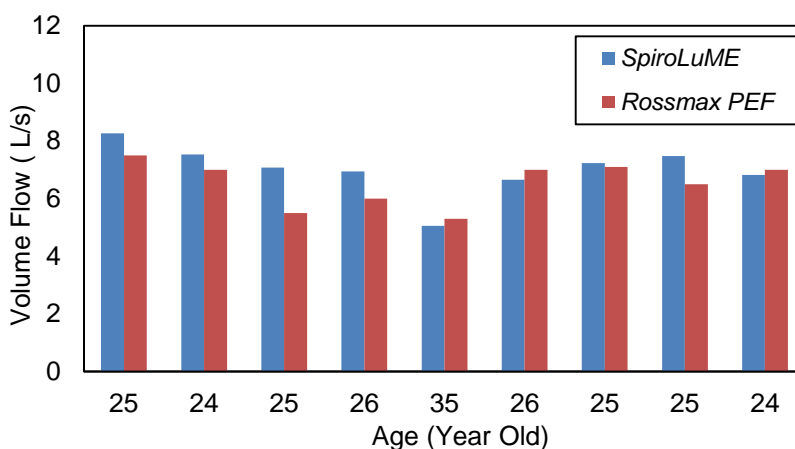

Fig. 4 Illustrated the preliminary test of the peak expiratory flow (PEF) of the patient

Figure 5 and **Figure 6** show readings for heart rate and SpO₂ level respectively for nine users of the *SpiroLuME* device. From the five readings taken and then the average of the data was calculated, the test gives each user a unique range, as seen above. The graph shows that user heart rates fluctuate. Except for three people, heart rate comparison data between the two devices is essentially tallied. *SpiroLuME* data ranges from 60 to 96 bpm. Some participants are active and healthy. The number may rise when the patient sits, speaks, or moves. The *BERRY Pulse Oximeter* is compared to this test. Based on all patients' heart rate data, we found a 60% re-semblance device percentage. The SpO₂ levels are 40% comparable due to sensor issues. The SpO₂ tests often read 95–100%. This test showed most *SpiroLuME* levels below 95% compared to *BERRY Pulse Oximeter* data. However, further investigation should also be conducted to update the current state of the device. In addition, accuracy testing and device validation should be conducted immediately to further strengthen the operational results and basic functionality of the *SpiroLuME* device and to test the lung capacity level of the patient's respiratory system. Moreover, the oxygen level data range is 94% - 98%. The efficiency of the device has been compared with the effectiveness of a medical device. As a result, the *SpiroLuME* device provides accurate and consistent PEF, SpO₂, and heart rate readings for all studied patients.

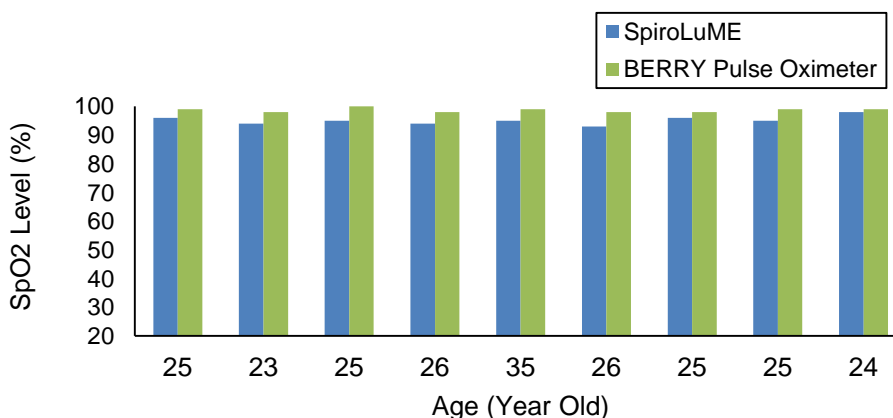

Fig. 5 Demonstrated the comparison test of the SpO₂ level (%) for 9 patients using a *SpiroLuME* device and *Berry Pulse Oximeter*

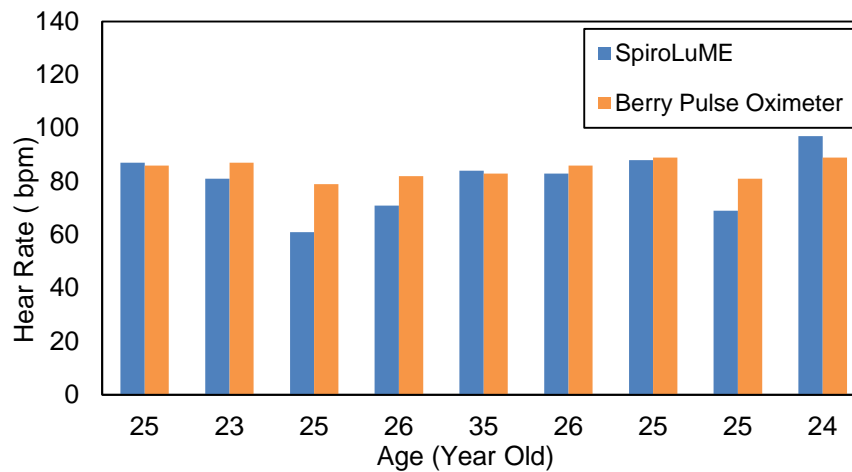

Fig. 6 Demonstrated the comparison test of the heart rate (HR) for 9 patients using a *SpiroLuME* device and *Berry Pulse Oximeter*

CONCLUSION

As a summary of the research that has been conducted, we concluded the development of *SpiroLuME* devices among doctors or medical experts is very important in improving the treatment process of respiratory system patients in Malaysia. Based on the 3 data, the PEF test shows, that the similarity for both data is 77% by comparing the device with the medical device. Moreover, the heart rate result fluctuates in the range of 61-97 bpm by all patients. For the oxygen level, the data of *SpiroLuME* ranges from 95% to the existing device which is above 97% and this is due to the technical issue of the sensor. By testing the consistency of data readings, especially heart rate (HR), oxygen levels (SpO₂), and PEF measurements, it proves that the *SpiroLuME* device has great potential to help patients with respiratory problems.

ACKNOWLEDGMENTS

This research work is strongly supported by the Ministry of Higher Education (MOHE) under FRGS/1/2021/TK0/UMP/02/25 grant, RDU210129, and RDU210332 from Universiti Malaysia Pahang Al-Sultan Abdullah (UMPSA) which provided the research materials and equipment. The authors have no conflicts of interest that are relevant to the content of this paper.

REFERENCES

- Elektronika, P., & Surabaya, N. (n.d.). Spirometer Non-Invasive dengan Sensor Piezoelektrik untuk Deteksi Kesehatan Paru-Paru kemalasari, paulus susetyo wardana, ratna adil (Vol. 5, Issue 2).
- Mubarak, W., Kumaidah, E., & Supatmo, Y. (2015). Media medika muda perbedaan nilai vital capacity, forced vital capacity dan forced expiratory volume in one second antar cabang olahraga pada atlet usia 6-12 tahun (Vol. 4, Issue 4).
- Jones Medical. (2017). A brief history of the spirometer. Jones Medical Instrument Company <https://www.jonesmedical.com/brief-history-spirometer>, last accessed 2022/12/12
- Zhang, T., Keller, H., O'Brien, M. J., Mackie, T. R., & Paliwal, B. (2003). Application of the spirometer in respiratory-gated radiotherapy. *Medical Physics*, 30(12), 3165–3171
- Karen L. Wood. (2022, April). Airflow, Lung Volumes, and Flow-Volume Loop. Grant Medical Center, Ohio Health. <https://www.msmanuals.com/professional/pulmonary-disorders/tests-of-pulmonary-function-pft/airflow,-lung-volumes,-and-flow-volume-loop> last accessed 2022/1/12
- Pérez, L. L. (2013). Office spirometry. In *Osteopathic Family Physician* (Vol. 5, Issue 2, pp. 65–69). <https://doi.org/10.1016/j.osfp.2012.09.003>
- Larissa Hirsch, M. (2019, September). Lungs and Respiratory System. Teen-sHealth.Org. <https://kidshealth.org/en/parents/lungs.prt-en.html> last accessed 2022/1/12
- Moore, V. C. (2012). Spirometry: Step by step. *Breathe*, 8(3), 233–240. <https://doi.org/10.1183/20734735.0021711> (accessed Dec. 15, 2022).
- Delgado BJ, Bajaj T. Physiology, Lung Capacity. [Updated 2021 Jul 26]. In: StatPearls [Internet]. Treasure Island (FL): StatPearls Publishing; 2022 Jan-. <https://www.ncbi.nlm.nih.gov/books/NBK541029/> last accessed 2022/1/12
- Lia andriani, Priyambada Cahya Nugraha, & Sari Lutfiah. (2019). Portable Spirometer for Measuring Lung Function Health (FVC and FEV1). *Journal of Electronics, Electromedical Engineering, and Medical Informatics*, 1(1), 16–20. <https://doi.org/10.35882/jeeemi.v1i1.4>
- Suresh, K., & Shimoda, L. A. (2016). Lung circulation. *Comprehensive Physiology*, 6(2), 897–943. <https://doi.org/10.1002/cphy.c140049>.
- Kalicka, R., Słomiński, W., & Kuziemski, K. (2008). Spirometry Measurement Model Diagnostic Purpose Support. In *Biocybernetics and Biomedical Engineering* (Vol. 28, Issue 3)
- Miller, M. R., Hankinson, J., Brusasco, V., Burgos, F., Casaburi, R., Coates, A., Crapo, R., Enright, P., van der Grinten, C. P. M., Gustafsson, P., Jensen, R., John-son, D. C., MacIntyre, N., McKay, R., Navajas, D., Pedersen, O. F., Pellegrino, R., Viegi, G., & Wagner, J. (2005). Standardization of spirometry. In *European Respiratory Journal* (Vol. 26, Issue 2, pp. 319–338).

14. Graham, B. L., Steenbruggen, I., Barjaktarevic, I. Z., Cooper, B. G., Hall, G. L., Hallstrand, T. S., Kaminsky, D. A., McCarthy, K., McCormack, M. C., Miller, M. R., Oropez, C. E., Rosenfeld, M., Stanojevic, S., Swanney, M. P., & Thompson, B. R. (2019). Standardization of spirometry 2019 update an official American Thoracic Society and European Respiratory Society technical statement. In *American Journal of Respiratory and Critical Care Medicine* (Vol. 200, Issue 8, pp. E70–E88). American Thoracic Society
15. Institute of Electrical and Electronics Engineers., & Institute of Electrical and Electronics Engineers. Region 8. (2007). EUROCON, 2007: proceedings: Model-ling of Spirometry. Diagnostic Usefulness of Model Parameters The International Conference on “Computer as a Tool”, September 9-12, 2007, Warsaw, Poland. IEEE.
16. Rahim, M.H.A., Adib, M.A.H.M., Hasni, N.H.M.: The comprehensive study of product criteria on Infant-Wrap (InfaWrap) device: an engineering perspective. *J. Phys. Conf. Ser.* 1529(5) (2020).
17. Rahim, M.H.A., Adib, M.A.H.M., Baharom, M.Z., Hasni, N.H.M.: Improving the Infant-Wrap (InfaWrap) device for neonates using MyI-Wrap mobile application. In: The 3rd Symposium on Intelligent Manufacturing & Mechatronics. The Lecture Notes in Mechanical Engineering (2020).
18. Rahim, M.H.A., Adib, M.A.H.M., Baharom, M.Z., Sahat, I.M., Hasni, N.H.M.: Non-invasive study: monitoring the heart rate and SpO₂ of the newborn using InfaWrap device. In: 2020 IEEE-EMBS Conference on Biomedical Engineering and Sciences (IECBES), 2021, pp. 212– 217.
19. Moschovis, P. P., & Hibberd, P. L. (2016). Pulse oximetry: An important first step in improving health outcomes, but it is of little use if there is no oxygen. In *Archives of Disease in Childhood* (Vol. 101, Issue 8, p. 685). BMJ Publishing Group.
20. Ralston, A. C., Webb, R. K., & Runciman, W. B. (n.d.). Potential errors in pulse oximetry I. Pulse oximeter evaluation*. In *Anaesthesia* (Vol. 46).
21. Van Ravenswaaij-Arts, C. M. A., Louis, Kollee, A. A., Jeroen, :, Hopman, C. W., Gerard, :, Stoeltinga, B. A., & van Geijn, H. P. (1993). Heart Rate Variability. In *Annals of Internal Medicine* (Vol. 118).

